

Cutlist:

- 1 1/2" x 3/16" Angle
- 2 pcs. - 40" long square ends
- 1 pc. - 17 1/8" 45 deg. P-F both ends
- 1 pc. - 17 1/8" coped both ends
- 2 pcs. - 35 1/2" long 45deg. P-F one end
- Note: Left and right on above
- 1 1/2" x 3/4" - 1/8" channel
- 2 pcs. - 17 1/2" long 45 deg P-F both ends
- 1 pc. - 11 3/4" long Square ends

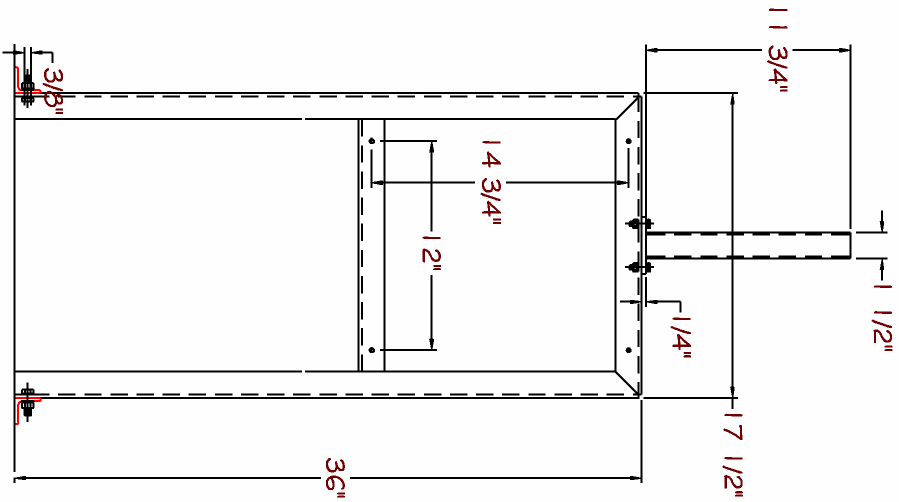
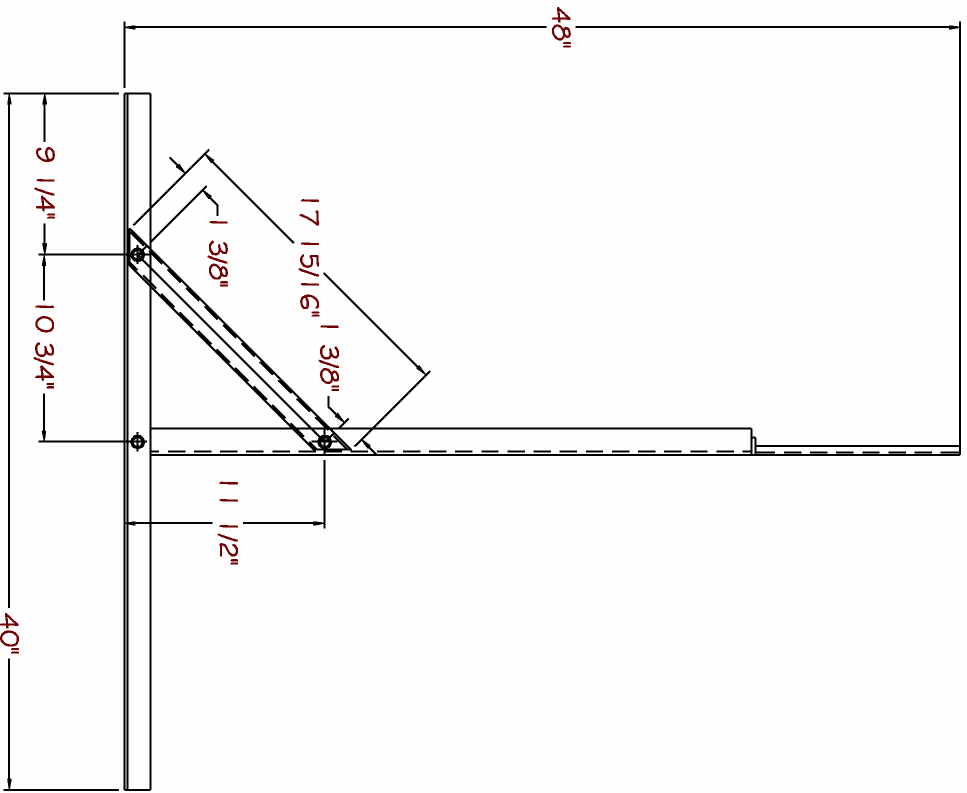

NOTES:

REV. 1

MATERIALS:

6061 Aluminum

FINISH:

Painted Finish

APPROVAL:

APPROV. FOR	REV.	DATE	REQD.	BY:	DESCRIPTION:

Detail of:
 Alum. Frame - Fan Box
 Free Standing Unit

Project Name & Location:

Contractor:

OBAR Systems

Architect:

Architect's Drawing References:

AWIS D1.1 Certified
 File Name: Obars_Systems_2011.dwg
 DRAWN by: Jim Smalik
 CHECKED:
 UNLESS OTHERWISE SPECIFIED:
 LINEAR TOLERANCES +/- .116"
 ANGULAR TOLERANCES +/- .1°

PRECISION WELDING
 "Quality Metal Fabricators"
 845 Berkshire Valley Road
 Whippany, NJ 07985
 (973) 214-1065
 (973) 895-1308 eFax

 www.precisionweld.com